

Medications to Avoid

Analgesics / Antipyretics

acetanilid, acetophenetidin (phenacetin), amidopyrine (aminopyrine) *, antipyrene *, aspirin *, phenacetin, probenecid, pyramidone

Miscellaneous

alpha-methyldopa, ascorbic acid *, dimercaprol (BAL), hydralazine, mestranol, methylene blue, nalidixic acid, naphthalene, niridazole, phenylhydrazine, toluidine blue, trinitrotoluene, urate oxidase, vitamin K * (water soluble), pyridium, quinine *

Antimalarials

chloroquine *, hydroxychloroquine, mepacrine (quinacrine), pamaquine, pentaquine, primaquine, quinine *, quinocide

Cytotoxic / Antibacterial

chloramphenicol, co-trimoxazole, furazolidone, furmethonol, nalidixic acid, neoarsphenamine, nitrofurantoin, nitrofurazone, para-aminosalicylic acid

Cardiovascular Drugs

procainamide *, quinidine *

Sulfonamides / Sulfones

dapsone, sulfacetamide, sulfamethoxypyrimidine, sulfanilamide, sulfapyridine, sulfasalazine, sulfisoxazole

Miscellaneous to Avoid

Fava Beans

(Few also avoid red wine, all legumes, blueberries [and yogurts containing these], soya products, tonic water, camphor).

Sources:

Ernest Beutler, M.D., Prof. Lucio Luzzatto, Prof. P. Marradi, Italian Health Ministry.

Safe to take

But only in normal therapeutic doses [!!!]

(Quoted from Ernest Beutler, M.D., "Glucose-6-Phosphate Dehydrogenase Deficiency," in *Erythrocyte disorders: Anemias due to increased destruction of erythrocytes with enzyme deficiencies*, p. 598.)

Acetaminophen (paracetamol, Tylenol, Tralgon, hydroxyacetanilide),
Acetophenetidin (phenacetin),
Acetylsalicylic acid (aspirin) *,
Aminopyrine (Pyramidon, amidopyrine) *,
Antazoline (Antistine),
Antipyrene *,
Ascorbic acid (vitamin C) *,
Benzhexol (Artane),
Chloramphenicol,
Chlorguanidine (Proguanil, Paludrine),
Chloroquine *, Colchicine,
Diphenhydramine (Benadryl),
Isoniazid, L-Dopa,
Menadione sodium bisulfite (Hykinone),
Menaphthone, *p*-Aminobenzoic acid,
Phenylbutazone, Phenytoin,
Probenecid (Benemid),
Procain amide hydrochloride (Pronestyl) *,
Pyrimethamine (Daraprim),
Quinidine *, Quinine *,
Streptomycin,
Sulfacytine, Sulfadiazine,
Sulfaguanidine,
Sulfamerazine,
Sulfamethoxypyridazine (Kynex),
Sulfisoxazole (Gantrisin),
Trimethoprim,
Tripelennamine (pyribenzamine),
Vitamin K *

* These drugs appear in both lists. Most prefer to avoid them altogether. If you do take these, please remember to take only **normal therapeutic doses**.

G6PD Deficiency Reference Guide

What is G6PD Deficiency?

Glucose-6-phosphate dehydrogenase (G6PD) deficiency is the most common human enzyme deficiency; it affects an estimated 400 million people worldwide.

G6PD deficiency is also known as "favism," since G6PD deficient individuals are also allergic to fava beans.

G6PD deficiency is a genetic condition that is inherited in an X-linked recessive fashion. This means that males are more likely to be affected by this condition than are females. Genetic testing is available to identify a deficiency in G6PD in both males and females.

It is very important to tell any doctor or other health professional (such as nurse or pharmacist) that you have G6PD Deficiency to avoid a possible harmful reaction to treatments they might prescribe.

What happens if you have G6PD Deficiency?

Hemolytic anemia and prolonged neonatal jaundice are the two major problems associated with G6PD deficiency. Both of these problems are directly related to the inability of specific cell types to regenerate a molecule called nicotinamide adenine dinucleotide phosphate in its reduced form (NADPH); this reaction is normally catalyzed by the G6PD enzyme. Aside from neonatal jaundice, hemolytic anemia can only arise when a person with G6PD Deficiency is exposed to certain chemicals; otherwise, they live a normal life.

Hemolytic anemia is the decreased ability of red blood cells to transport oxygen throughout the body; consequently, if you are having a hemolytic crisis, you will probably feel tired and out of breath, and may have a dark colored urine. Certain oxidative drugs, infections, or fava beans (and the pollen from the fava bean plant) can cause this. When any one of these agents enters the red blood cell, hemoglobin becomes denatured, thus destroying its function as the principle oxygen carrying molecule.

In normal cells, NADPH would play a role in removing these harmful oxidants from the cell. Among the drugs

contra-indicated for G6PD deficient individuals are aspirin and most anti-malarial drugs; fortunately, G6PD deficient individuals are resistant to malarial infection. Treatments for hemolytic anemia include nasal oxygen, bed rest, human haptoglobin products, folic acid, and blood transfusions.

Neonatal jaundice (a yellowing of the mucous membranes and other body tissues at birth) is a common condition in all newborns, but when it persists, G6PD deficiency is suspected. The newborn becomes jaundiced as a result of decreased activity of G6PD in the liver. This can be a potentially serious problem as it can cause severe neurological complications. Jaundiced babies are placed under special lights, called bili-lights, to alleviate the jaundice.

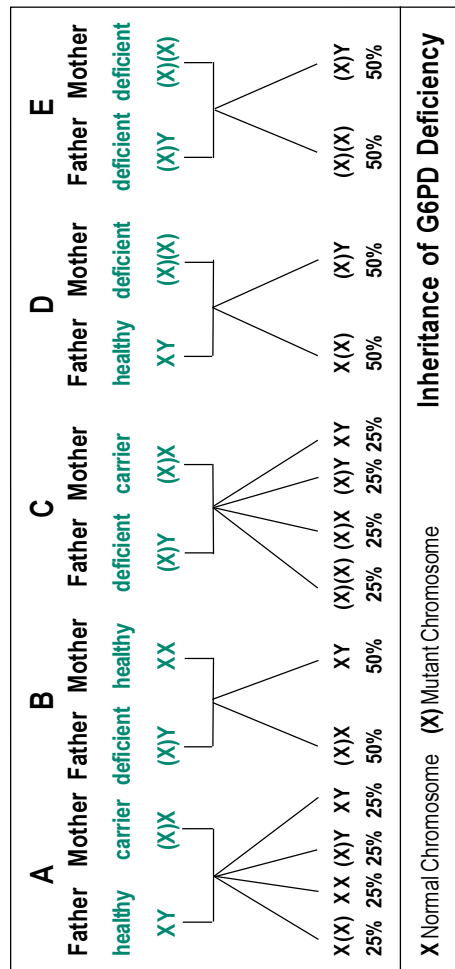

Frequently Asked Questions

How do I get G6PD Deficiency?

G6PD Deficiency is an inherited condition; therefore, you can not get it from being in contact with someone who has G6PD Deficiency. Since it is inherited, there is no cure.

What are the chances of passing it on to my kids?
[see diagram at left]

A) If the father is unaffected (healthy) and the mother is a carrier (no clinical symptoms):

- One daughter out of two will be a carrier
- One son out of two will be G6PD deficient

B) If the father is G6PD deficient and the mother is unaffected:

- All daughters will be carriers
- All sons will be unaffected

C) If the father is G6PD deficient and the mother is a carrier:

- One daughter out of two will be G6PD deficient
- One daughter out of two will be a carrier
- One son out of two will be G6PD deficient
- One son out of two will be unaffected

D) If the father is unaffected and the mother is G6PD deficient:

- All daughters will be carriers
- All sons will be G6PD deficient

E) If both father and mother are G6PD deficient:

- All daughters will be G6PD deficient
- All sons will be G6PD deficient

What precautions can I take to ensure my health?

Do not take any of the medications listed in this brochure (or medications similar to them) without consulting a physician. Also avoid fava beans (and the plant). Always tell any health provider you see that you have G6PD Deficiency (and give them this list).

What are the symptoms of hemolytic anemia?

Am I having a reaction?

You will begin to feel tired, short of breath, have an irregular heart beat, and may have a dark orange urine.

Can I donate blood if I have G6PD Deficiency?

No! Currently the Red Cross does not accept G6PD deficient blood.

How would you call fava beans in other languages?

Arabic: Foolle;

Catalan: Fava;

Chinese: Tzan-Doo;

Dutch: Tuinboon;

Farsi (Persian): Ba-ghe-Leh;

English: Fava or Broad Bean;

French: Fève;

German: Favabohnen (Fava bean), Dicke Bohnen (thick bean), Saubohnen (sow bean);

Greek: Koukia ("Fava" is an appetizer made from dried fava beans);

Italian: Fava (pl. fave);

Kurdish: Paqla;

Malay: Kacang Parang;

Spanish: Haba;

Turkish: Bakla ("Fava" is an appetizer made from dried fava beans);

Urdo (Pakistan and India): Lobhiya, Rajma, Jheam.

[Excerpted from the Favism & G6PD Deficiency Forum]

For a more thorough discourse, go to:

<http://www.g6pd.org>

<http://www.favism.org>

You may also join our new **G6PD Deficiency and Favism Forum** where you can exchange opinions and consult with other members (<http://www.g6pd.org/g6pdforum>).

Updated and published by Associazione Italiana Favismo - Deficit di G6PD (ONLUS)

<http://www.favism.org>

While all effort has been made to ensure that the information offered here is correct and up-to-date, neither the authors of included content, nor the Favism Site and G6PD Deficiency Site their employees, affiliates, agents and third party information providers warrant that the information is accurate and complete. Under no circumstances shall the above be liable for any direct, indirect, incidental, special or consequential damages that result from the use of said information, nor shall they be liable for errors or omissions.

The purpose of this brochure is to offer the reader a background information on favism and G6PD Deficiency. No recommendation brought herein should be followed without prior consultation with your physician.